



**RGV SERIES
VERTICAL IN-LINE
MULTISTAGE PUMP**

REGALINE RGV series vertical in-line stainless steel multistage pumps are designed and manufactured using the latest technology to provide a single pump solution to high pressure applications. Its precise engineering ensures easy installation and servicing with no alignment problems associated with conventional centrifugal pumps, and is ideal for quiet running, energy saving and space saving requirements.

Pump

- All wetted hydraulic parts are of stainless steel construction.
- In-line suction and discharge can be fitted with oval/round flanges or PJE, Clamp, Union, DIN coupling.
- For pumps with a higher number of stages, the load thrust is absorbed by the bearing and coupling thus long service life of pump and motor is ensured.
- Long life laser-welded impellers.
- Mechanical seal in compliance with EN12756 and ISO3069 standards.

Motor

- Single phase
Up to 2.2kW, 220-240V 50Hz 2 pole, IP55, Class F insulation, IEC V18.
- Three phase
380-415V 50Hz 2 pole, IP55, Class F insulation, IEC V18 or V1 (according to motor power).
- Different frequencies (eg. 60Hz) and voltages can be supplied upon request.
- Overload protection to be provided by user.

Identification Code

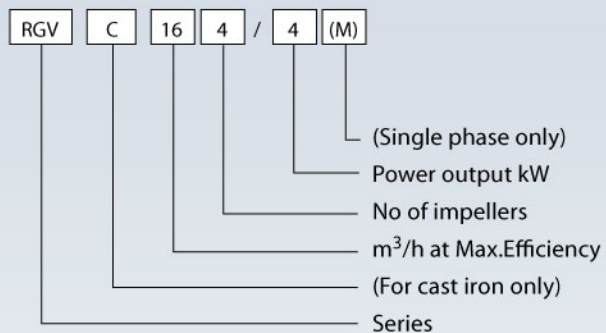

Operating Conditions

- Capacity : 2-110 m³/h
- Head : 5-300 m
- Suitable for handling clean, non-flammable and non-explosive liquid containing no solid particles and fibres.
- Normal temperature type : -15°C ~ +70°C
- Hot water type : +70°C ~ +120°C
- Ambient temperature : up to 40°C
- Altitude : up to 1000 m.

Applications

- Industrial
- Civil
- Fire protection
- Jockey pump system
- Booster system
- Hydropneumatic system
- Variable speed booster system
- Water treatment plants (reverse osmosis, filtration)
- Irrigation
- Air conditioning
- Boiler system



Material of Construction

Ref.	Parts	Materials
1	Pump body	Stainless steel AISI304
2	Impeller	Stainless steel AISI304
3	Diffuser	Stainless steel AISI304
4	Shaft	Stainless steel AISI316
5	Outer sleeve	Stainless steel AISI304
6	Mechanical seal	Tungsten carbide / carbon
7	Coupling	Cast iron
8	Motor	-
9	Motor adaptor	Cast iron
10	Lower bearing	Tungsten carbide
11	Base mount	Cast iron
12	Elastomer	EPDM / Viton
13	Bushing	Tungsten carbide
14	Shaft sleeve	Stainless steel
15	Wear ring	Glass-filled teflon

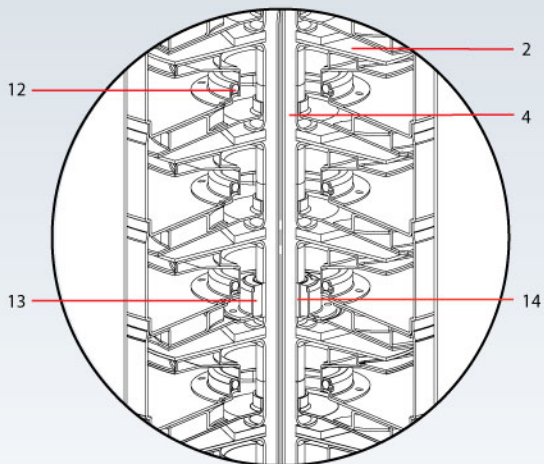
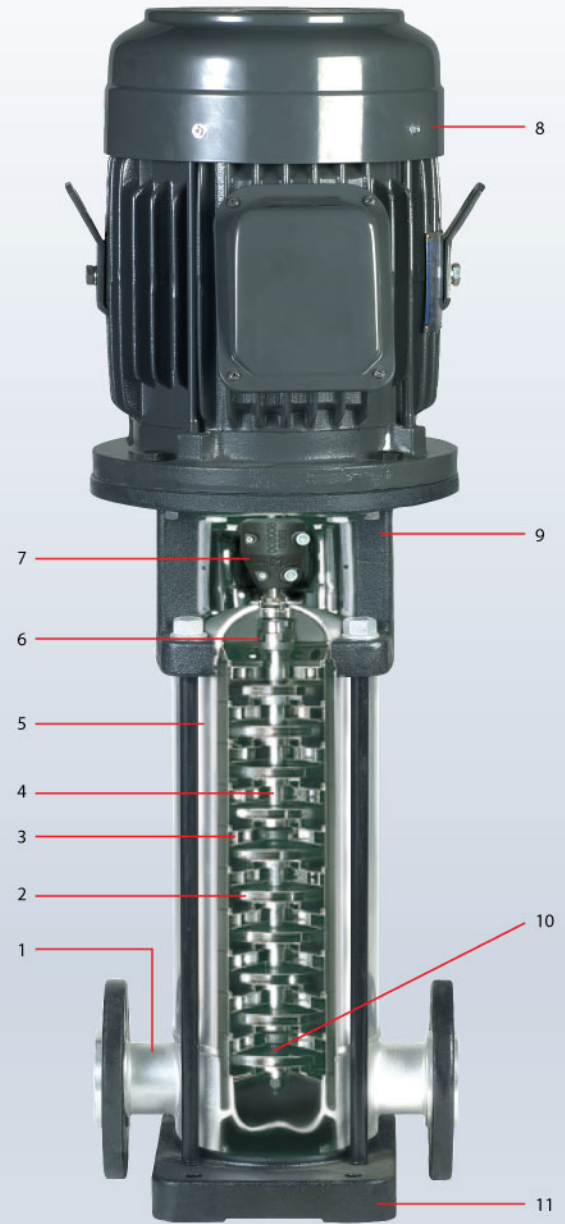

RGV 1 - RGV 20

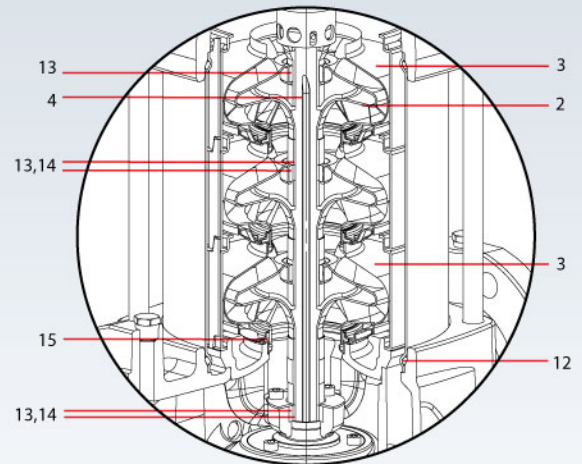

RGV 32 - RGV 90

Selection Range Chart

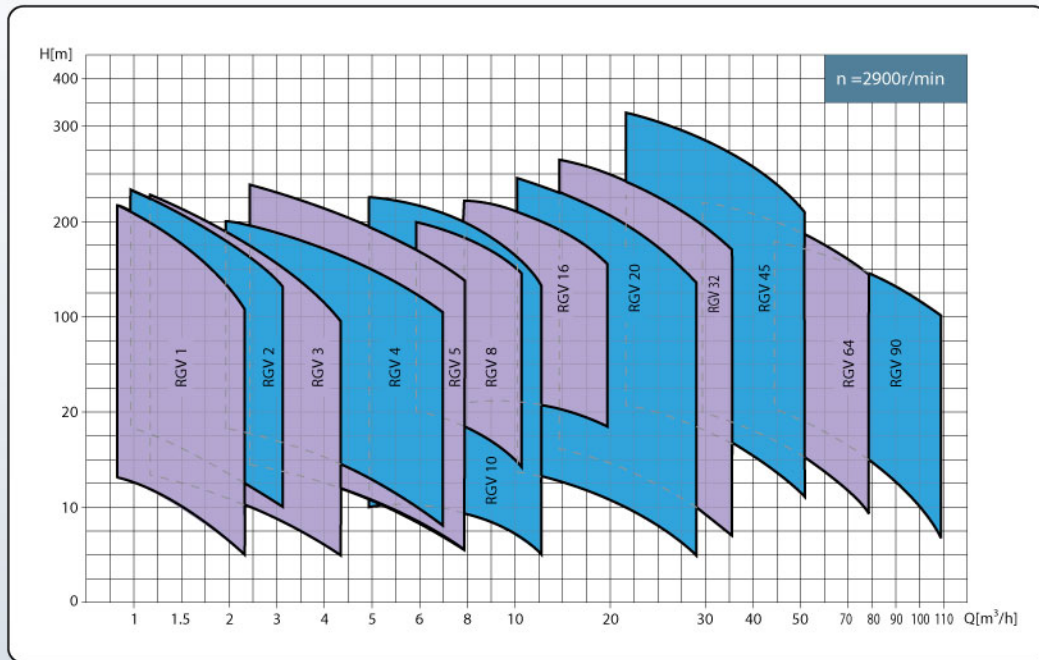

Product Range

Model	RGV 1	RGV 2	RGV 3	RGV 4	RGV 5	RGV 8	RGV 10	RGV 16	RGV 20	RGV 32	RGV 45	RGV 64	RGV 90
Rated flow (m³/h)	1	2	3	4	5	8	10	16	20	32	45	64	90
Flow range (m³/h)	0.7 - 2.4	1.0 - 3.5	1.2 - 4.4	2 - 7	2.5 - 8	6 - 11	5 - 13	8 - 22	10.5 - 29	15 - 36	22 - 55	30 - 80	45 - 110
Max. pressure (bar)	22	25	24	22	24	22	22	23	25	27	32	22	20
Motor power (kW)	0.37 - 2.2	0.37 - 3.0	0.37 - 3.0	0.37 - 4.0	0.37 - 5.5	0.75 - 7.5	0.37 - 7.5	2.2 - 15	1.1 - 18.5	1.5 - 30	3.0 - 45	4.0 - 45	5.5 - 45
Temperature range (°C)	-15 to + 120												
Max. efficiency (%)	48	48	58	59	66	64	70	70	72	78	79	80	81
Type													
RGVC	-	-	-	-	-	○	○	○	○	○	○	○	○
RGV	○	○	○	○	○	○	○	○	○	○	○	○	○
Pipe connection													
PI / PO Clamp	Rp1	Rp1	Rp1	Rp1 ¼	Rp1 ¼	-	-	-	-	-	-	-	-
PJE Coupling	○	○	○	○	○	○	○	○	-	-	-	-	-
DIN Flange	DN25/32	DN25/32	DN25/32	DN25/32	DN25/32	DN40	DN 40	DN50	DN50	DN65	DN80	DN100	DN100

○ available - not available

For enquiries, please contact :